

R RotoPack®

PACKAGING MACHINES

MADE IN ITALY
SINCE 1994



RPG 15/6
CONFEZIONATRICE ROTATIVA 6 POSIZIONI
ROTARY FILL-SEAL MACHINE 6 STATIONS



ROTOPACK SRL

Via Carbonari, 16 - 20030 PADERNO DUGNANO (MI - ITALY) - Tel. +39.02.99044396 - Fax +39.02.99042582

info@rotopacksrl.com - www.rotopacksrl.com

Caratteristiche tecniche

- ✓ Disegnata per essere semplice, flessibile, affidabile, competitiva
- ✓ Adatta per il confezionamento di **gelato in coppe**
- ✓ Completamente realizzata in acciaio inox e alluminio anodizzato
- ✓ Funzionamento elettro meccanico assistito pneumaticamente
- ✓ Cambio formato rapido
- ✓ In linea con le norme alimentari e con le direttive CE
- ✓ Può essere personalizzata con: datario, metti-coperchio a pressione, lubrificazione centralizzata, ecc.
- ✓ Possibilità di saldare e fustellare film da bobina (optional)

Technical features

- ✓ Designed to be simple, user friendly, reliable and competitive
- ✓ Suitable to pack **cups of ice-cream**
- ✓ Completely made in stainless steel and anodized aluminium
- ✓ Electro-mechanical working concept pneumatically served
- ✓ Fast tool change
- ✓ In conformity with alimentary rules and CE directives
- ✓ Can be customized with: coder, snap-on cap dispenser, centralized lubrication etc.
- ✓ Can seal film from coil (optional)

Caractéristiques techniques

- ✓ Dessinée pour être simple, flexible, fiable et compétitive
- ✓ Apte au remplissage de **glace en pots**
- ✓ Complètement réalisée en acier inox et aluminium anodisé
- ✓ Fonctionnement électromécanique assisté pneumatiquement
- ✓ Changement de format rapide
- ✓ Conforme aux règles alimentaires et directives CE
- ✓ Peut être personnalisée avec: codeur, couvercle a pression, lubrification automatique etc.
- ✓ Peut sceller et couper film en bobine (optionnel)

Technische Merkmale

- ✓ Eigens ausgelegt auf Einfachheit, Flexibilität, Zuverlässigkeit und Wettbewerbsfähigkeit
- ✓ Geeignet für das Abfüllen von **Eis im Becker**
- ✓ Vollständig aus Edelstahl und eloxiertem Aluminium hergestellt
- ✓ Pneumatisch unterstützte elektromechanische Funktion
- ✓ Schneller Formatwechsel
- ✓ Entspricht den Lebensmittelgesetzen und den EG- Richtlinien
- ✓ Kann personalisiert werden mit: Datumsstempel, Aromaschutzdeckel- Aufsetzer, zentralisierter Schmierung usw.
- ✓ Möglichkeit zum Schweißen und Stanzen von Film von der Rolle (Option)

Tensione	Power	Puissance	Spannung	400 V - 50/60 Hz - 3P + N + PE
Motore	Motor	Moteur	Motor	0,55 Kw
Potenza assorbita	Power consumption	Consommation	Leistungsaufnahme	0,70 Kw
Aria compressa	Air supply	Consommation pneumatique	Druckluft	350 Lt/min
Pressione	Air pressure	Pression aire	Druck	6 bar
Peso	Weight	Poids	Gewicht	420 Kg.
Capacità produttiva	Output	Cadence	Produktionskapazität	Max 2800 pz/h
Max dimensione contenitori	Max. Container dimensions	Max. Dimensions pots	Max. Abmessungen behälter	Diam. 95 mm
Dimensioni macchina	Machine dimensions	Dimensions de la machine	Abmessungen dermaschine	mm. 1000 x 1100 x 1470
Max volume riempimento	Filling volume	Volume de remplissage	Max. volumen	500 cc

RPG 15/6

CONFEZIONATRICE ROTATIVA
6 POSIZIONI

ROTARY FILL-SEAL MACHINE
6 STATIONS

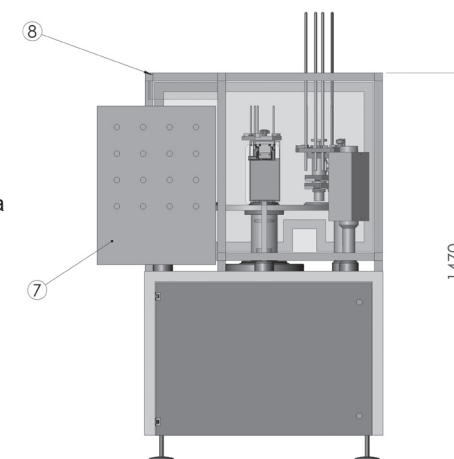
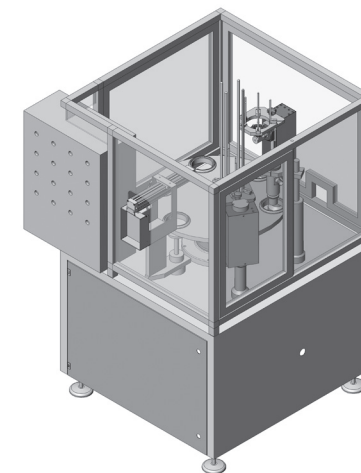

- 1) Magazzino contenitori
- 2) Dosatore
- 3) Magazzino coperchi
- 4) Stazione libera
- 5) Stazione libera
- 6) Estrazione
- 7) Quadro comandi
- 8) Protezione antinfortunistica

- 1) Container dispenser
- 2) Dosing unit
- 3) Lid dispenser
- 4) Free station
- 5) Free station
- 6) Ejection
- 7) Control panel
- 8) Safety guard

- 1) Dépôt pots
- 2) Dosage
- 3) Dépôt opercules
- 4) Station libre
- 5) Station libre
- 6) Expulsion
- 7) Panneau électrique
- 8) Protection

- 1) Behältermagazin
- 2) Dosiervorrichtung
- 3) Deckelmagazin
- 4) Freie station
- 5) Freie station
- 6) Entnahme
- 7) Schalttafel
- 8) Unfallschutzeinrichtung

